

Small Engine Parts and Operation

INTRODUCTION

The small engines used in lawn mowers, garden tractors, chain saws, and other such machines are called *internal combustion engines*. In an internal combustion engine, fuel is burned *inside* the engine to produce power. The internal combustion engine produces mechanical energy directly by burning fuel.

In contrast, in an *external combustion engine*, fuel is burned *outside* the engine. A steam engine and boiler is an example of an external combustion engine. The boiler burns fuel to produce steam, and the steam is used to power the engine. An external combustion engine, therefore, gets its power indirectly from a burning fuel.

In this course, you'll only be learning about small internal combustion engines. A "small engine" is generally defined as an engine that produces less than 25 horsepower.

In this study unit, we'll look at the parts of a small gasoline engine and learn how these parts contribute to overall engine operation. A small engine is a lot simpler in design and function than the larger automobile engine. However, there are still a number of parts and systems that you must know about in order to understand how a small engine works.

The most important things to remember are the *four stages of engine operation*. Memorize these four stages well, and everything else we talk about will fall right into place. Therefore, because the four stages of operation are so important, we'll start our discussion with a quick review of them. We'll also talk about the parts of an engine and how they fit into the four stages of operation. Note that this will just be a simple overview. Later in the study unit, we'll talk about the parts of an engine and their operation in much more detail.

The Four Stages of Engine Operation

Let's start by discussing some basic ideas we covered earlier in the course. These topics are so important that it won't hurt to review them. First, you know that the main moving part in a small engine is the *piston*. The piston is a round, can-shaped metal device that fits into a round metal opening called the *cylinder*. The piston can move up and down inside the cylinder. The top of the cylinder is sealed by the *cylinder head*. The other end of the piston is connected to a rod and crankshaft assembly.

Remember that when a piston is at its lowest position in the cylinder, it's said to be at *bottom dead center (BDC)*. When the piston is at its highest position in the cylinder, it's said to be at *top dead center (TDC)*.

Inside the cylinder, the space above the piston is called the *combustion chamber*. In the combustion chamber, a mixture of air and fuel is burned to produce power. When the air-and-fuel mixture burns in the combustion chamber, it actually produces a small, contained explosion. This explosion is strong enough to force the piston downward in the cylinder.

When the piston is forced downward in the cylinder, the piston's downward motion is transferred to the rod and crankshaft. The rod and crankshaft then convert the up-and-down motion of the piston into *rotary motion* (circular motion). A simplified drawing of the cylinder, piston, and crankshaft is shown in Figure 1.

FIGURE 1—A simplified drawing of the cylinder, piston, and crankshaft is shown here.

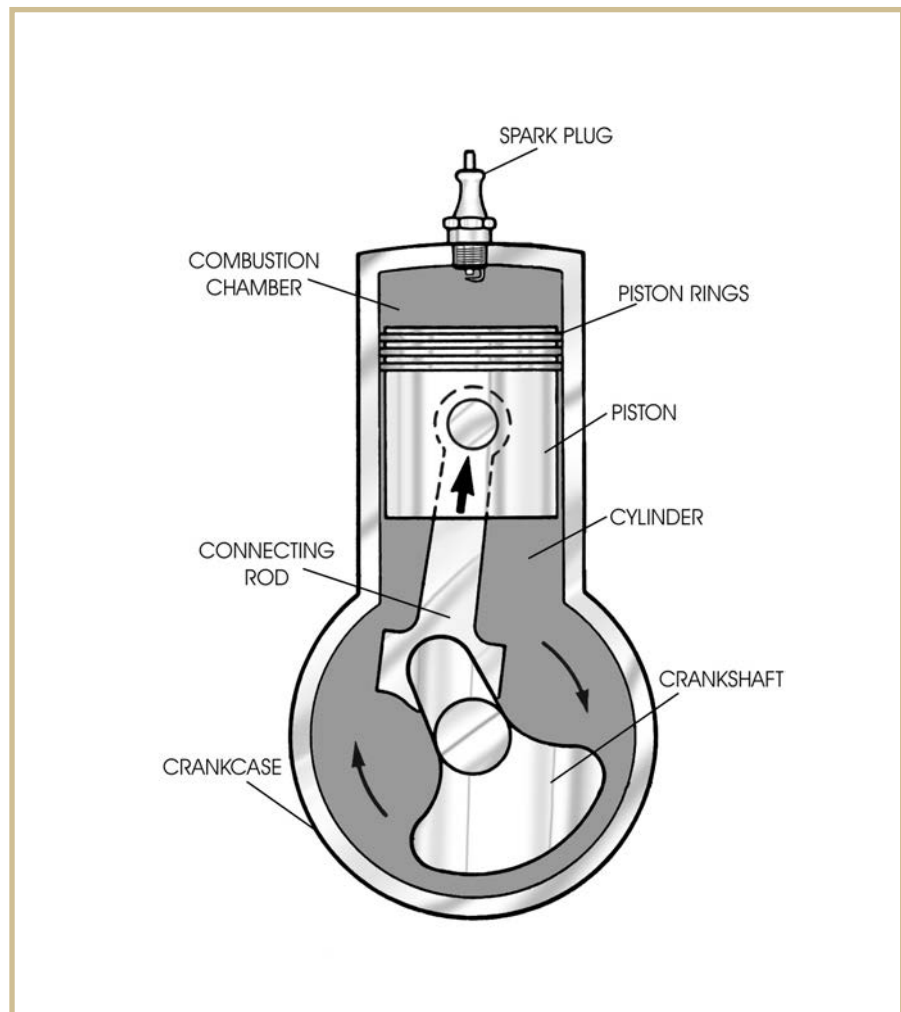

This conversion of up-and-down motion to rotary motion can be compared to the motion produced by a regular bicycle. When you pedal a bike, you push down on the pedals with your feet. The downward motion of your feet on the pedals is converted into circular motion in the rear wheel of the bike. The same principle applies to an engine.

The downward motion of the piston is converted to circular motion that can be used to power a piece of equipment.

In order to work, all gasoline engines must do four basic actions. An engine must

1. Take in fuel
2. Squeeze or compress the fuel
3. Ignite and burn the fuel
4. Get rid of the burned gases

The engine actions we've just described are the four stages of engine operation. The proper names for these stages are *intake*, *compression*, *power*, and *exhaust*. When an engine is operating, it continually runs through these four stages, over and over again.

Stage 1: In the *intake stage*, air that has been mixed with fuel is drawn into the cylinder.

Stage 2: In the *compression stage*, the piston rises, compressing the air-and-fuel mixture trapped in the combustion chamber.

Stage 3: During the *power stage*, the air-and-fuel mixture is ignited, and the contained explosion of the fuel presses the piston back down in the cylinder. The downward motion of the piston is transferred to the rod and crankshaft.

Stage 4: During the *exhaust stage*, the exhaust gases are released from the cylinder. The four stages then begin all over again.

One engine *cycle* is a complete "run" through all four stages of operation. Note that the four stages of operation that we've described occur very quickly, and they repeat continuously for as long as the engine is running.

Now that you understand the basics of engine operation, let's look at a comparison of the two-stroke engine and the four-stroke engine.

Two-Stroke Engines and Four-Stroke Engines

Two-stroke engines and *four-stroke engines* are both used in outdoor power equipment applications. However, the internal operation of the two types of engines are different. The basic difference between two-stroke engines and four-stroke engines is the way in which they run through the four stages of operation. (When we're talking about engines, remember that the *stroke* of an engine is the distance that the piston travels up and down in a cylinder.)

In order for any engine to operate, it must run through all four stages of operation. In a four-stroke engine, four strokes of the piston are required to complete the four stages of operation, as follows:

Stroke 1: Intake stage

Stroke 2: Compression stage

Stroke 3: Power stage

Stroke 4: Exhaust stage

In contrast, in a two-stroke engine, only two strokes of the piston are needed to complete the four stages of operation:

Stroke 1: Intake stage/Compression stage

Stroke 2: Power stage/Exhaust stage

So, in a two-stroke engine, the intake and compression stages are completed by one stroke of the piston. The power and exhaust stages are completed by the second stroke of the piston.

Basic Four-Stroke Engine Operation

Let's take a closer look at the operation of the four-stroke engine. A simplified drawing of a four-stroke engine is shown in Figure 2. Note the position of the piston, the cylinder, and the crankshaft. The *crankshaft* is connected to the piston by a *connecting rod*. The *spark plug* is positioned at the top of the engine over the combustion chamber.

FIGURE 2—The parts of the four-stroke engine are clearly labeled for you in this illustration. During the intake stage, the piston lowers to suck the air-and-fuel mixture into the cylinder. The intake valve is open and the exhaust valve is closed.

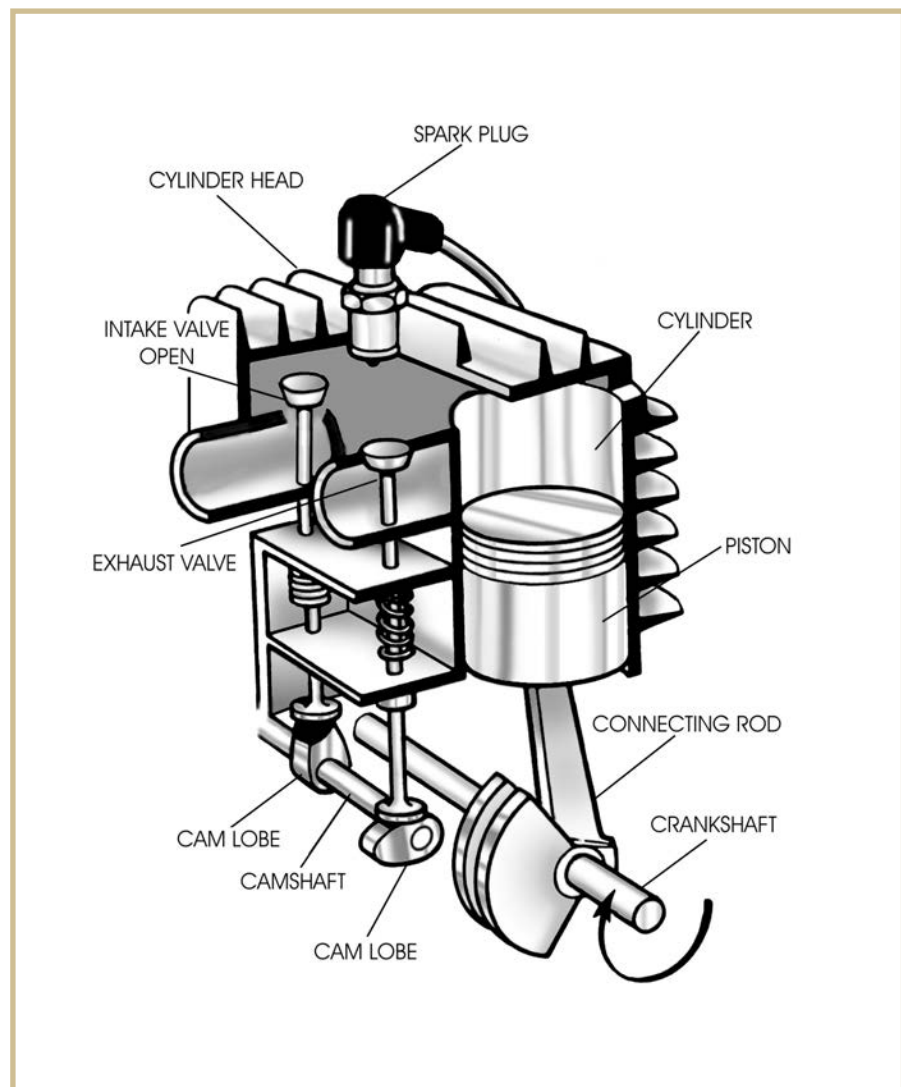

The four-stroke engine contains two mechanical valves: the *intake valve* and the *exhaust valve*. These valves lift up and down to open and close during engine operation. The intake valve opens to allow the air-and-fuel mixture to flow into the combustion chamber, and the exhaust valve opens to allow exhaust gases to flow out of the engine after the fuel is burned.

The intake and exhaust valves are mechanically lifted to make them open and close. The valves are lifted by *valve lifters* that rest on the *lobes* of the *camshaft*. As the camshaft turns, the lobes lift the valves in a timed sequence to match up properly with the up-and-down motion of the piston.

In order to burn properly in an engine, fuel must be mixed with air. The part that does this is the *carburetor*. Fuel moves from the fuel tank into the carburetor where it's vaporized and mixed with air. The air is taken in through an *air intake port*. The air-and-fuel mixture is then transferred out of the carburetor and into the cylinder through the *intake valve*.

A four-stroke engine completes the four stages of engine operation in four piston strokes. During the *intake stage*, the intake valve opens and the piston moves down in the cylinder. As the piston moves down, a vacuum is created that sucks the air-and-fuel mixture into the cylinder through the intake valve. The intake valve is held open at this time by one of the lobes on the camshaft. The exhaust valve is closed. Figure 2 illustrates the intake stage.

When the piston reaches bottom dead center, both valves are closed. The air-and-fuel mixture is now trapped inside the sealed combustion chamber. At this point, the piston begins to rise, compressing the air-and-fuel mixture tightly. This is the *compression stage*, which is illustrated in Figure 3.

The piston rises until it reaches top dead center. At that moment, the engine's ignition system is timed to make the spark plug "fire." That is, the ignition system produces electric current that causes a spark to jump across the two electrodes of the spark plug. Naturally, when a spark is applied to a compressed mixture of fuel and air, an explosion occurs and the fuel mixture is burned.

When gases explode, they expand rapidly. The force of this contained explosion forces the piston down in the cylinder. Since the piston is connected to the crankshaft through the connecting rod, the piston's downward movement causes the crankshaft to turn around. This is the *power stage*, which is illustrated in Figure 4.

As the piston moves downward during the power stage, the exhaust valve opens. By the time the piston reaches bottom dead center, the exhaust valve is completely open. As the piston rises back up, it pushes the burned gases out of the exhaust valve. The exhaust gases then pass out of the engine. This is the *exhaust stage*, which is illustrated in Figure 5.

Once the exhaust stage is completed, the four stages of operation begin all over again. The movement of the camshaft closes the exhaust valve and opens the intake valve, and the piston moves down to begin a new intake stage.

FIGURE 3—In the compression stage, both valves are closed. As the piston rises, it compresses the air-and-fuel mixture in the sealed combustion chamber.

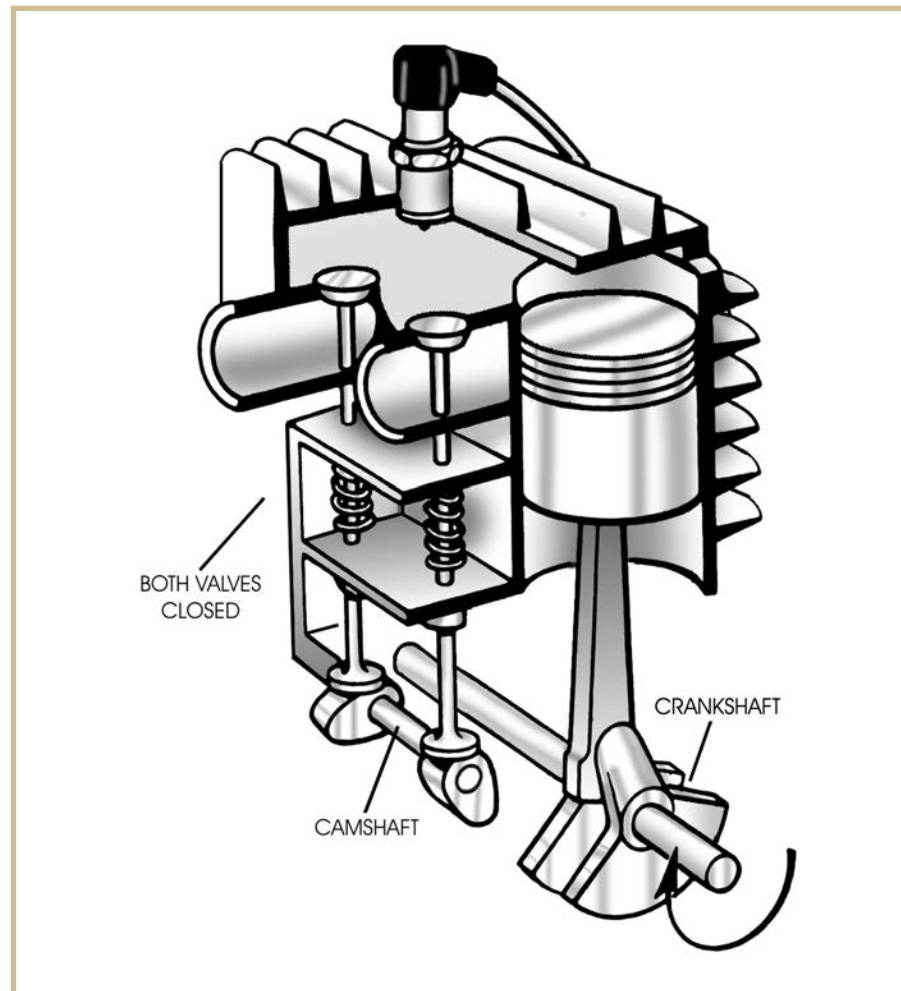

Basic Two-Stroke Engine Operation

Although a two-stroke engine has many of the same components as a four-stroke engine, its operation is very different. In a two-stroke engine, one power stroke occurs for each rotation of the crankshaft. (In contrast, you'll remember that in a four-stroke motor, one power stroke occurs for every *two* rotations of the crankshaft.)

So, remember that the two-stroke engine must go through the same four stages of engine operation—intake, compression, power, and exhaust—that a four-stroke engine does. However, the two-stroke engine goes through all four stages in just *two piston strokes*. Each time the piston moves up, it completes the intake and compression stages. Each time the piston moves down, it completes the power and exhaust stages.

Two-stroke engines are much simpler in design than four-stroke engines. The simplest two-stroke engine has only three moving parts: the piston, the connecting rod, and the crankshaft. Two-stroke engines don't use the same type of mechanical valves in the combustion chamber that a four-stroke engine does. Instead, the two-stroke engine has holes in the cylinder wall called *ports*. As the piston slides up and down in the cylinder, it covers and uncovers the ports, allowing the air-and-fuel mixture into the cylinder and forcing the exhaust gases out.

FIGURE 4—When the piston reaches top dead center, the spark plug fires and ignites the air-and-fuel mixture. The force created by the exploding fuel gases pushes the piston down in the cylinder. This is the power stage.

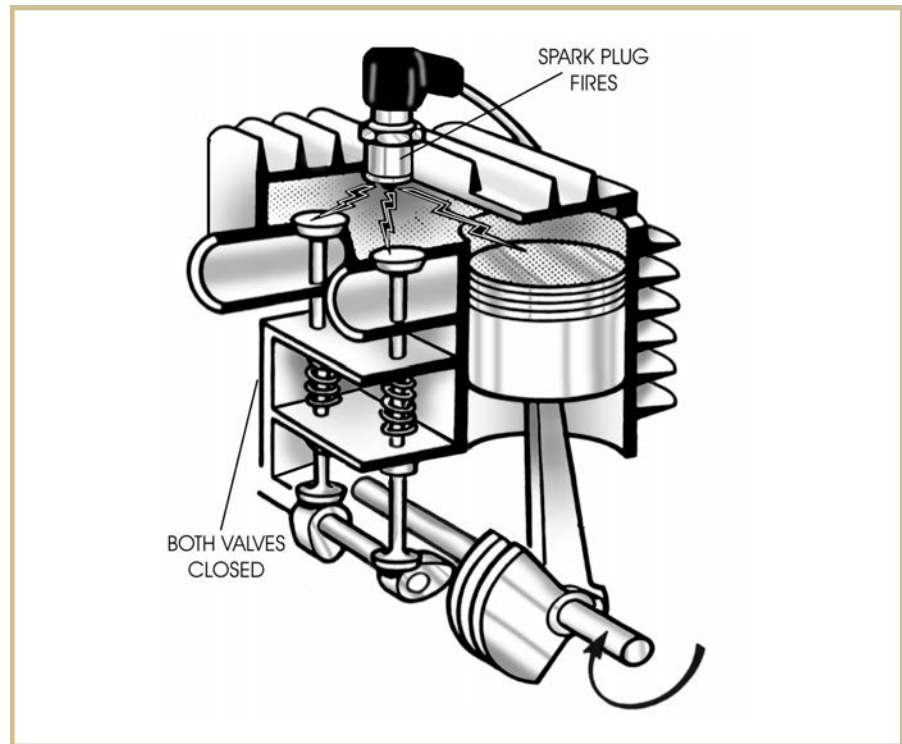
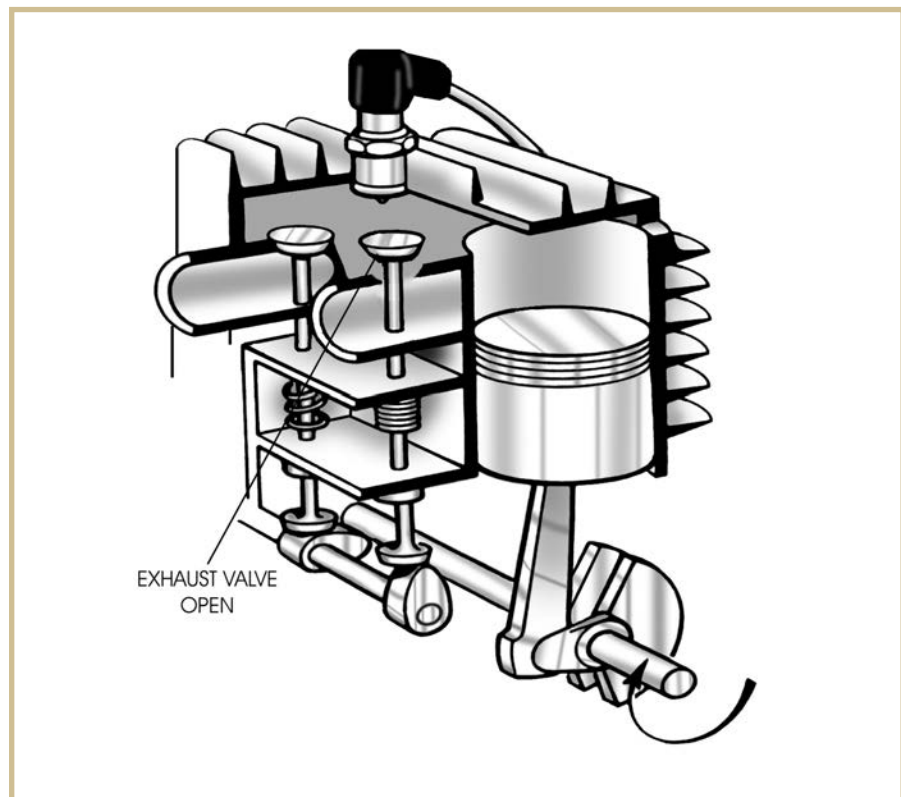
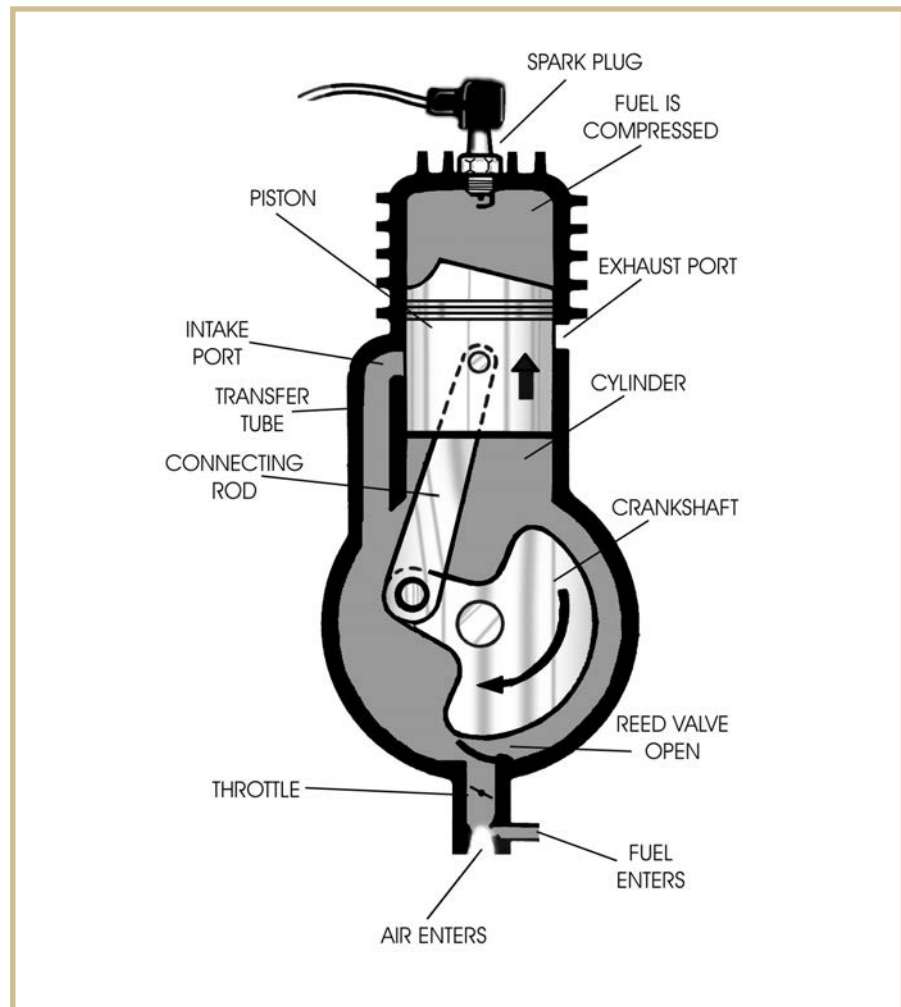

FIGURE 5—When the piston moves down during the power stage, the exhaust valve opens. The piston then rises again and pushes the burned gases out of the exhaust valve.



The intake/compression stage of a two-stroke engine is illustrated in Figure 6. During the intake/compression stage, the piston begins to move up in the cylinder, creating a vacuum in the crankcase below the piston. The vacuum sucks in fuel and air through the carburetor to fill the crankcase. Note the small *reed valve* that's positioned at the point where the air-and-fuel mixture enters the crankcase. This valve is a small piece of fiberglass or spring steel that bends back to allow fuel to enter the crankcase.

FIGURE 6—The intake /compression stage of a two-stroke engine is shown here. The piston rises, creating a vacuum in the crankcase. Air and fuel are sucked into the crankcase through the reed valve. At the same time, the air-and-fuel mixture that's already in the combustion chamber is compressed. Both the intake port and the exhaust port are closed. The reed valve is open.



During this stage, note that the piston covers both the intake port and the exhaust port. Some air-and-fuel mixture is already in the combustion chamber. As the piston rises, it compresses this air-and-fuel mixture that's already in the combustion chamber. (In the figure, observe the positions of the intake and exhaust ports—they're not directly across from each other. This allows the piston to cover one of the ports at a time.)

The power/exhaust stage of the two-stroke engine is illustrated in Figure 7. During this stage, the spark plug fires and the air-and-fuel mixture burns. The expanding gases produced by the burning air-and-fuel mixture force the piston down in the cylinder. As the piston begins to move down in the cylinder, note that the two ports are still closed.

Because the two ports are still closed, the downward motion of the piston creates pressure that presses down on the air-and-fuel mixture in the crankcase. At this time, the reed valve in the crankcase is also closed because the air-and-fuel mixture is pressing down on it.

FIGURE 7—The beginning of the power/exhaust stage of the engine is shown here. Both ports are still closed. The reed valve is also closed during this stage. The downward motion of the piston forms a vacuum that presses down on the air-and-fuel mixture in the crankcase.

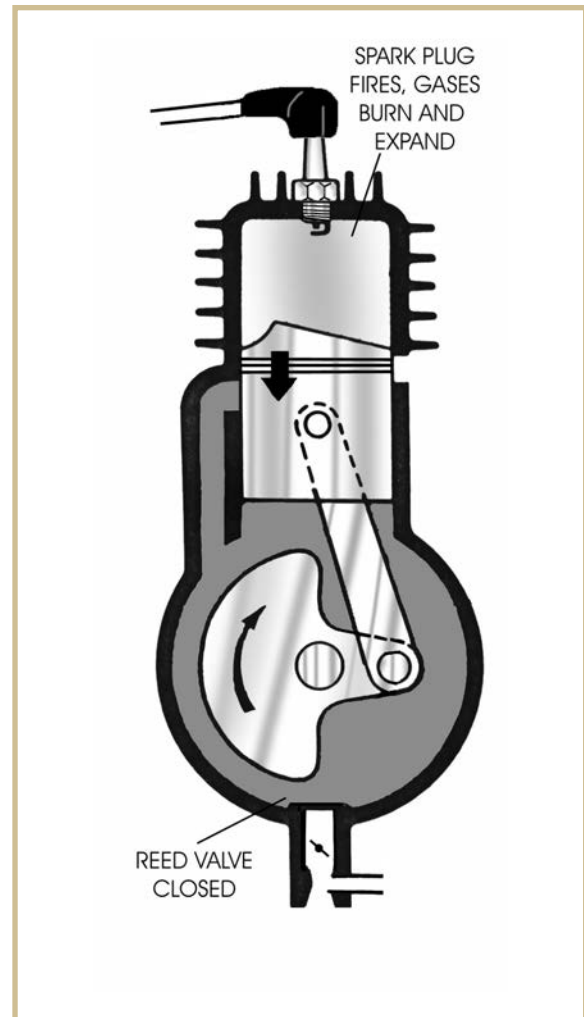

The end of the power/exhaust stage is shown in Figure 8. As the piston reaches bottom dead center, the two ports are opened. The exhaust gases are expelled out of the engine, and at the same time, the air-and-fuel mixture from the crankcase flows into the combustion chamber through the intake port. This occurs because the piston is pressing down on the air-and-fuel mixture in the crankcase and forcing it into the transfer tube. The *transfer tube* is simply a tube that connects the crankcase to the intake port. The air-and-fuel mixture being forced into the combustion chamber helps force the exhaust gases out. The intake/compression stage then begins again.

Note that the four stages of operation in a two-stroke engine overlap each other a bit. In the intake/compression stage of the two-stroke engine, air-and-fuel mixture is sucked into the crankcase at the same time that the piston is compressing the air-and-fuel mixture in the combustion chamber.

FIGURE 8—The end of the power/compression stroke is shown here. The exhaust gases escape through the exhaust port, and at the same time, more air-and-fuel mixture enters the combustion chamber through the intake port.

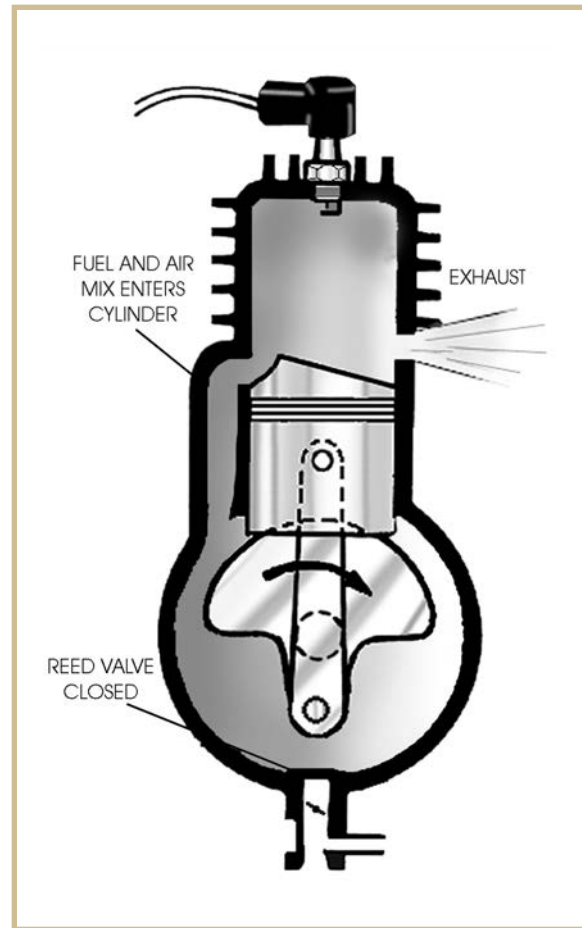

During the power/exhaust stage, the air-and-fuel mixture flows into the combustion chamber at the same time that the exhaust gases are escaping. In contrast, in the four-stroke engine, these four stages are more clearly separated from each other.

The term “intake” also has a slightly different meaning in the two-stroke engine than in a four-stroke engine. In the two-stroke engine, air-and-fuel mixture is taken into the *crankcase* during the intake stage. In contrast, in a four-stroke engine, the air-and-fuel mixture enters the *cylinder* during the intake stage.

Two-stroke engines are usually simple in construction and they operate efficiently. However, these engines do have some disadvantages. First, a two-stroke engine must rotate faster to produce the same power output as a four-stroke engine. This faster rotation causes quicker wear of the engine’s moving parts. Second, in a two-stroke engine, the lubricating oil must be mixed with the air-and-fuel mixture. Thus, the oil burns along with the air-and-fuel mixture, causing pollution.

In contrast, the crankcase of a four-stroke motor is filled with oil that’s not burned, but simply splashed on the internal engine parts to lubricate them.

Engine Power and Speed

Let's take a moment now to review the factors that determine an engine's power and speed. The intake, compression, power, and exhaust stages of operation cause an engine to rotate at a certain speed. The speed of operation depends on the amount of air-and-fuel mixture that's allowed to enter the cylinder. The more air-and-fuel mixture that reaches the cylinder, the faster the engine's crankshaft will rotate. The faster the crankshaft rotates, the more air that will be drawn into the engine. If the amount of air-and-fuel mixture that reaches the cylinder is reduced, the crankshaft will turn slower.

When an engine is at its lowest operating speed, the engine is said to be at *idle speed*. At idle speed, an engine produces very little power. However, once the speed of the engine increases, the power of the output shaft of the motor also increases. In outdoor power equipment, this power increase is used to turn a lawn mower blade, operate a chain saw, or perform other such work.

The speed at which an engine operates is measured in units called *revolutions per minute (rpm)*. The rpm is a measure of how fast the crankshaft is turning, that is, how many complete turns the crankshaft can make in one minute. At idle speed, a typical motor revolves at approximately 700 rpm. As the flow of air and fuel increases at the intake port of the engine, the engine rotates at a much higher rpm until it reaches the maximum value set by its manufacturer. Depending on the engine model, the maximum rpm value is between approximately 3,000 rpm and 7,000 rpm. Note that if an engine is modified to run faster than its rated rpm, the engine may be destroyed by the large reciprocating and centrifugal forces present within its components.

Horsepower

Most small engines are rated in units called *horsepower (hp)*. One horsepower is therefore equal to 550 foot-pounds of work per second. Today, almost all small engines are identified by their horsepower output. For example, many lawn mowers contain engines with ratings between 3 hp and 5 hp. Garden tractors are available with engines rated at 9 hp, 10 hp, 12 hp, or more. The higher the horsepower of the engine, the stronger the engine is and the more work it can perform.

Remember that the maximum power output of an engine is the *brake horsepower (bhp)*. You'll usually see the specifications for an engine given in units of bhp. In practical use, an engine that was always run at maximum would have a very short life span. For this reason, engine specifications are also given in units called *rated horsepower*. The rated horsepower of an engine is normally considered to be about 80 percent of the engine's maximum horsepower.

For example, an engine with a maximum brake horsepower of 10 bhp would have a rated horsepower of 8 hp, since 8 is equal to 80 percent of 10. The rated horsepower of an engine is often printed on the outside of the engine and can also be found in the manufacturer's manual.

Rated horsepower is useful when you need to determine what size engine is needed for a particular machine. If the machine requires 8 hp to operate, you would choose an engine that has a rated horsepower of 8 hp or a maximum horsepower of 10 bhp.

The horsepower rating of an engine is normally given along with the rpm value of the engine. For example, an engine may be rated for 10 hp at 4,000 rpm. Figure 9 displays a graph of horsepower versus rpm. Note that this graph displays a curve rather than a straight line. Also, note that horsepower will decrease after a certain rpm value is reached.

FIGURE 9—As you can see by this graph, horsepower increases with engine rpm.

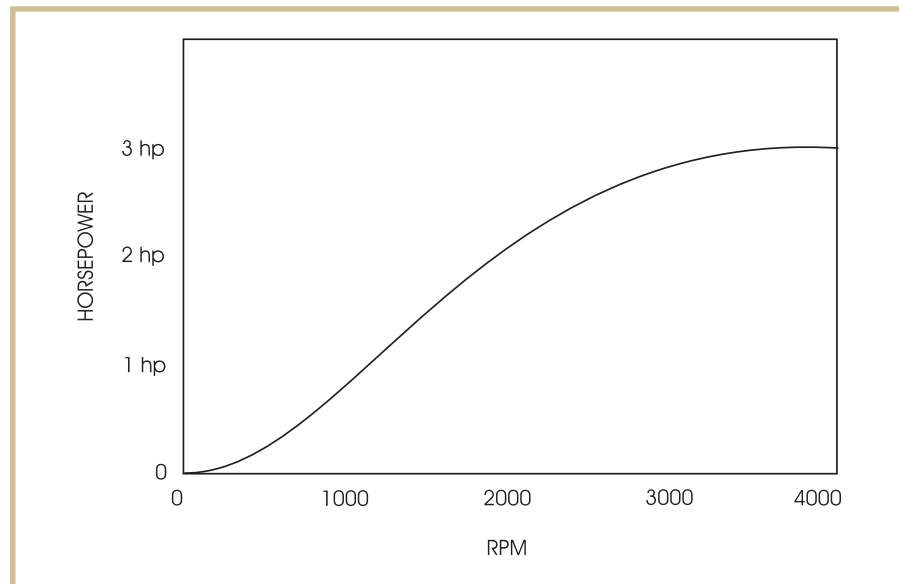

Torque

Another quantity that's often used to rate engines is *torque*. Torque is the twisting force produced at the output shaft of the motor. Engine torque values are normally measured in units called *foot-pounds*. The torque value of an engine increases with an increase in rpm.

As you've probably figured out by now, the ideal engine would have high horsepower and lots of torque. Unfortunately, this combination of qualities doesn't happen often in real life. In a typical engine, horsepower generally increases as the rpm increases. The maximum horsepower develops near the maximum rpm limit of the engine. Torque, on the other hand, is produced somewhat differently. In a typical engine, the maximum torque will normally be produced at a lower rpm, then decline as the rpm increases. This means that the maximum torque and the maximum rpm don't usually occur at the same time. Thus, engine selection is a compromise, depending on the particular application.

Displacement

Engine *displacement* is the volume of space that the piston moves as it moves from the bottom dead center to top dead center. The distance that the piston travels up and down in a cylinder is called the *stroke* of the engine. Displacement is measured in cubic inches.

The displacement of an engine will usually be stated in the service manual for an engine, or printed on the engine itself.

You can calculate the displacement of an engine if you know the diameter of the cylinder and the length of the stroke of the engine. The displacement of an engine can be calculated by using the following formula:

$$\text{displacement} = \frac{\pi(d^2)(s)(n)}{4}$$

In the formula, the symbol π stands for the constant pi, which is always equal to 3.14. The letter d stands for the diameter of the cylinder. The 2 after the letter d means that the diameter must be *squared* in the equation. (To square a number, simply multiply the number times itself). The letter s stands for the length of the stroke of the engine. The letter n stands for the number of cylinders in the engine.

An engine's displacement value has an effect on the power that the engine develops. In most cases, the larger the displacement, the more power the engine will develop.

Compression Ratio

When a piston is at its lowest point in the cylinder (BDC), the volume of the cylinder is at its largest. When the piston is at its highest point in the cylinder (TDC), the volume of the cylinder is at its smallest. The ratio of the largest cylinder volume to the smallest cylinder volume is called the *compression ratio*.

An engine's compression ratio will determine how much the fuel mixture is compressed when the piston rises. The higher the compression ratio, the more the fuel mixture will be compressed. So, if an engine has a compression ratio of 5 to 1, it means that the volume of the cylinder at BDC is 5 times higher than the volume of the cylinder at TDC.

When the air and fuel mixture in the cylinder is compressed, the pressure of the mixture increases dramatically. This large increase in pressure will make the mixture burn stronger when it's ignited. In general, the higher the compression ratio of the engine, the stronger the fuel mixture will burn and the faster the engine will run. Most small gasoline engines have a compression ratio of between 5 to 1 and 6 to 1.

Now, take a few moments to review what you've learned by completing *Power Check 1*.

Power Check 1

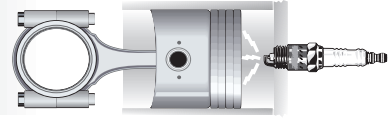

At the end of each section of your *Small Engine Parts and Operation* text, you'll be asked to check your understanding of what you've just read by completing a "Power Check." Writing the answers to these questions will help you review what you've learned so far. Please complete *Power Check 1* now.

1. *True or False?* In an external combustion engine, fuel is burned inside the engine.
2. In the _____ stage, the piston rises, compressing the air-and-fuel mixture trapped in the combustion chamber.
3. When a piston is at its lowest position in the cylinder, it's said to be at _____.
4. During the _____ stage, gases are released from the cylinder.
5. A typical one-cylinder, four-stroke engine contains two valves called the _____ valve and the _____ valve.
6. In a four-stroke engine, the part that mixes fuel with air is the _____.
7. In the _____ stage, air mixed with fuel is drawn into the cylinder.
8. *True or False?* A two-stroke engine completes all four stages of engine operation in four piston strokes.
9. The units of rpm measures how fast the _____ is turning in an engine.
10. During the _____ stage, the mixture of air and fuel is ignited, and the contained explosion of the fuel presses the piston back down in the cylinder.

Check your answers with those on page 61.

BASIC ENGINE COMPONENTS

Now that we've reviewed the important basics of engine operation, let's begin our discussion about small engine parts. We'll cover all the basic parts of an engine and explain how they function. Note that almost all of these basic parts are found in both four-stroke engines and two-stroke engines. However, the arrangement of the parts will vary slightly in different types of engines.

Figure 10 shows four views of the same four-stroke engine. Figure 10A is an external view of the front of the engine, and Figure 10B is an external view of the rear of the engine. In Figure 10C, the blower housing has been removed from the engine, and several internal components are visible. Finally, in Figure 10D, the crankcase cover (the very bottom cover) of the engine has been removed, and other components are visible. Many of the major components are labeled in these photos for you.